

Digital Undercounter ecostore HP Concept Refrigerated Counter - 2 Door (60Hz)

ITEM # _____

MODEL # _____

NAME # _____

SIS # _____

AIA # _____

710248 (EK2RBAAH)

 2-door Refrigerated
 Counter, -2+10°C, AISI 304
 (R134a), UK plug - 60 Hz

Short Form Specification

Item No. _____

AISI 304 stainless steel panels, AISI 430 bottom panel, galvanized back panel. Worktop thickness 50mm. N. 2 full doors. Built-in refrigeration unit. Operating temperature: -2+10°C. R134a gas in refrigeration circuit. Supplied with 1 grid for each door compartment

Main Features

- Adjustable temperature range from -2 °C to +10 °C to suit meat, fish and dairy storage requirements.
- Refrigerated compartment designed to accept GN 1/1 containers.
- Combination of doors and drawers to suit varying needs, with the possibility to change the configuration on site.
- Digital control panel.
- Forced air circulation for rapid cooling and an even temperature distribution.
- Anti-tilt runners accept GN 1/1 containers.
- Self closing stainless steel doors (< 90°).
- Fully compliant HACCP digital control: when temperature exceeds critical limits, acoustic and visual alarms are activated. Up to two months of event are kept in memory.
- Prearranged to fit RS485 port to facilitate connection to a remote computer and integrated HACCP systems.
- 0mm clearance installation space: tower configuration cooling unit guarantee performance with frontal ventilation only; this unique solution allows installation against the wall or side by side with other appliances, even on the cooling unit side to maximize the use of kitchen space.
- Hot gas automatic evaporation of defrost water.
- Preservation performances and temperature uniformity within the cell guaranteed at 5-HEAVY DUTY (40°C) working conditions according to EN16825:2016 test protocol.
- Combination of doors and drawers to suit any configuration needed, with the possibility to change the configuration on site. Right cooling unit available on request.
- Frontal and easy access to all components in the cooling unit.
- Certified safety CE requirements.
- Equipped with forced air circulation system for rapid cooling and temperature distribution within the cell.
- External bottom panel in stainless steel.
- External back panel in galvanized steel.
- Connectivity ready for real time access to connected appliances from remote and data monitoring (requires optional accessory).
- Easy serviceability thanks to the intuitive control panel with access via app.
- Integrated RS485 port to facilitate connection to a remote computer and integrated HACCP systems.

Construction

- Pre-arranged for drain-pipe.
- Built-in compressor to suit operating conditions.
- Constructed from AISI 304 Stainless steel throughout to meet the highest hygiene standards.
- Rounded internal corners for ease of cleaning.
- Mounted on Stainless steel adjustable legs to give 150 mm clearance for ease of cleaning.
- Access to all components from the front.

APPROVAL: _____

- Developed and produced in ISO 9001 and ISO 14001 certified factory.
- Fault code display.
- Internal and external doors, front and side panels and removable worktop in AISI 304 Stainless steel.
- Worktop in AISI 304 Stainless steel with a 50 mm profile.
- Anti-drip profile on stainless steel worktop edge.
- 2 compartments with 2 doors.
- If needed, working top can be removed for easier handling during installation (in case of narrow doors).
- Ease of cleaning and high hygiene standards thanks to the rounded internal corners, the easily removable runners, grids and air conveyors.
- Internal structure with 15 charging positions (3 cm pitch) available to host GN 1/1 grids, ensuring higher net capacity and a greater storage space.
- Excellent space optimisation thanks to the compact dimensions.
- Extractable cooling unit to facilitate maintenance.

Sustainability



- CFC and HCFC free (ecological refrigerant type: R134a, - gas in foam: cyclopentane).
- Removable triple-chamber balloon magnetic gasket to improve insulation and reduce energy consumption and ease of cleaning.
- Top energy efficiency (class A) and granted uniformity even at extreme working conditions (class 5; 40°C and 40% humidity): unbeatable performance, certified by energy test protocol EN16825:2016.
- Fitted with 90 mm thickness of cyclopentane insulation for best insulating performance (thermal conductivity: 0,020 W/m*K) and lowest environmental impact (GWP=3).

Included Accessories

- 2 of Kit 1/1 grey rilsan grid and 2 side runners for refrigerated counters PNC 881109

Optional Accessories

- 2x½ drawer kit for refrigerated counters PNC 881058
- 3x1/3 drawer kit for refrigerated counters PNC 881059
- 1/3 and 2/3 bottle drawer kit for refrigerated counters PNC 881071
- 1/1GN grey rilsan grid for refrigerated counters PNC 881107
- 2 side runners for 1/1 GN ecostore refrigerated counters PNC 881108
- Kit 1/1 grey rilsan grid and 2 side runners for refrigerated counters PNC 881109
- 1/1 GN plastic container, H=65 mm PNC 881110
- 1/1 GN plastic container, H=100 mm PNC 881111
- 1/1 GN plastic container, H=150 mm PNC 881112
- Kit 4 wheels, H=100 mm (2 with brakes) for refrigerated counters PNC 881191
- Kit 4 wheels, H=150 mm (2 with brakes) for 2&3 compartment refrigerated counters PNC 881193
- Lock for refrigerator/freezer counters with 2 compartments - h700mm (can be used in kit for Marine conversion) PNC 881242

Front

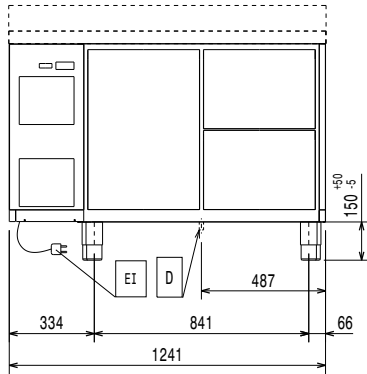

Side

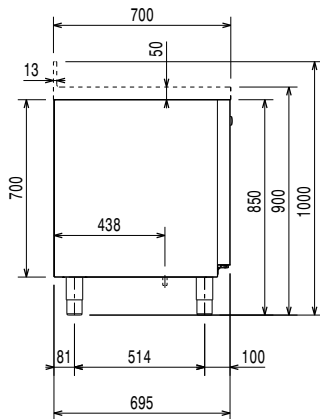

EI = Electrical inlet (power)

Top

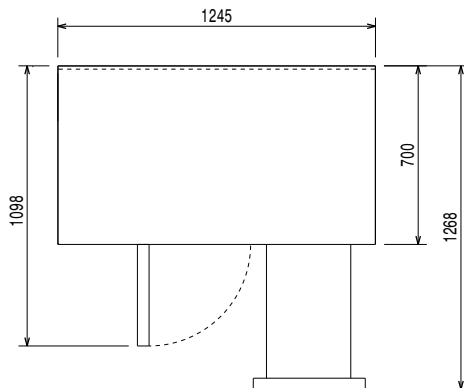

Electric

Supply voltage:

710248 (EK2RBAAH) 220-230 V/1 ph/60 Hz

Key Information:

Gross capacity: 290 lt
Net Volume: 181 lt
Door hinges: 1 Left+1 Right
Built-in Compressor and Refrigeration Unit
External dimensions, Width: 1245 mm
External dimensions, Depth: 700 mm
External dimensions, Height: 900 mm
Depth with doors open: 1110 mm

Refrigeration Data

Compressor power: 1/4 hp

ISO Certificates

ISO Standards: ISO 9001; ISO 14001; ISO 45001; ISO 50001

Sustainability

Refrigerant type: R134a
Refrigeration power: 0 W
Refrigerant weight: 100 g